

STANDARD EQUIPMENT

SHAFT STRUCTURE

Galvanized steel structure made of cold rolled special profiles, premounted in 2-m-sections incl. trunking.

CABIN

made of folded galvanized steel sheets, centered suspension, guided on both sides with adjustable guide shoes. All units on serving height are supplied with a removable shelf. Increments of 25 mm available.

LANDING DOORS

Approved to DIN 18092 resp. 18090 as a bi-parting, single or double hinged type available. Approved door locks. Bi-parting doors suspended with 2 high flexible steel ropes, guided with aluminium sheaves in cage. All doors with pre-installed frame surrounds for easy installation.

MACHINE ROOM DOOR

Single hinged door, double hinged for width over 800 mm galvanized finish, with lock, incl. frame surrounds.

COUNTERWEIGHT

Steel frame with 50 x 50 mm inserts. Adjustable guide shoes with polyamid inserts.

DRIVE UNIT

Up to 100 kg capacity with sheave drive for 2 or 3 ropes. Units with 200 and 300 kg capacity with chain drive for 2 chains. High quality reduction gear with motor, magnetic disc brake and handwheel. Insulation class IP 54.

CONTROLLER

- 24 Volt system on all push button units
- Pre-wired as plug-in-system
- Call and send operation on each landing station
- Despatching delay device
- Arrival buzzer and call signal
- Position indicator on each landing station



SERVICE LIFTS

Beside the proven standard lift types ISO-A, ISO-C and ISO-D, special designs are available for all clients requirements in compliance with local national regulations.

- Drive units on the side** If no sufficient space in headroom is available, the drive unit can be positioned above or below at side of the shaft.
- Adjacent entrances** 2 or 3 opening sides available.
- Safety gear** Requested on shafts with spaces underneath.
- Ship lifts** With safety gear and controller in compliance to Lloyds rules and regulations.
- Undercounter lifts** For installation in kitchens and bars under a counter with a min. installation height.
- Explosion proof** Available on request for chemical industry, paint stocks or mills.
- Automatic lifts** E.g. for stocks and mail distribution.

Deviating dimensions and specifications on demand.

Type	Capacity	Door height (DH)	Speed	Cabin dimensions (variable in 25 mm increments)		Shaft dimensions mm		Pit depth / Serving height mm P / Sh	Min. headroom mm
				width	depth	width	depth		
ISO-A Vertical bi-parting doors on serving height	50 kg	600 - 1200 mm	0,4 m/s	400 - 600	400 - 600	cabin width + 300	cabin depth + 150	Sh = min. 700	serving height + door height + 1260
	100 kg	600 - 1200 mm	0,4 m/s	400 - 1000	400 - 1000	cabin width + 300	cabin depth + 150	Sh = min. 700	serving height + door height + 1260
	300 kg	600 - 1200 mm	0,25 m/s	400 - 1000	400 - 1000	cabin width + 300	cabin depth + 150	Sh = min. 700	serving height + door height + 1360
ISO-C Vertical bi-parting doors serving at floor level	100 kg	600 - 1200 mm	0,27 m/s	500 - 1000	500 - 1000	cabin width + 350	cabin depth + 150	P = min. DH / 2 + 50	door height + 1260
	300 kg	600 - 1200 mm	0,25 m/s	500 - 1000	600 - 1000	cabin width + 350	cabin depth + 150	P = min. DH / 2 + 50	door height + 1360
ISO-D Swing doors serving at floor level	100 kg	600 - 1200 mm	0,27 m/s	400 - 1000	500 - 1000	cabin width + 350	cabin depth + 110	P = min. 350	door height + 1260
	300 kg	600 - 1200 mm	0,25 m/s	400 - 1000	600 - 1000	cabin width + 350	cabin depth + 110	P = min. 350	door height + 1360

10 ADVANTAGES

- Quality seal along DIN EN ISO 9001:2008
- Custom-made solutions
- Environment-friendly production
- Corrosion protection by fire galvanization
- Quick and easy installation (with installation manual)
- Installation in existing buildings possible
- Easy operation – very user-friendly
- Low need of current
- Low noise level
- Minimum maintenance

ISO-A

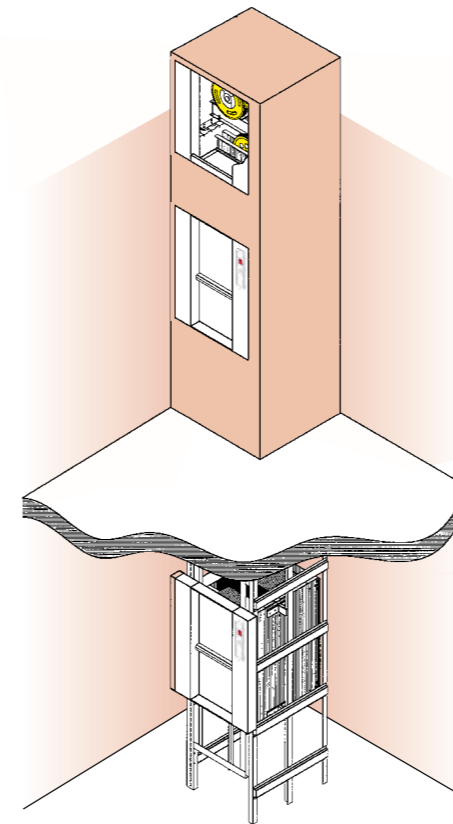

Vertical bi-parting doors on serving height

ISO-C

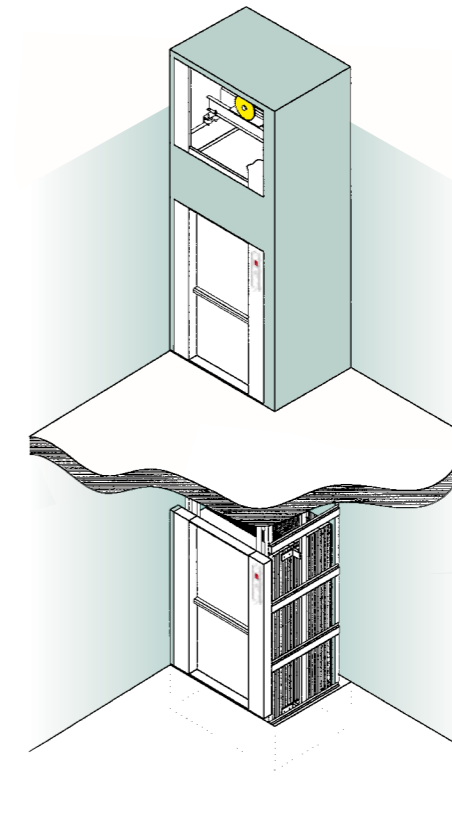

Vertical bi-parting doors serving at floor level

ISO-D

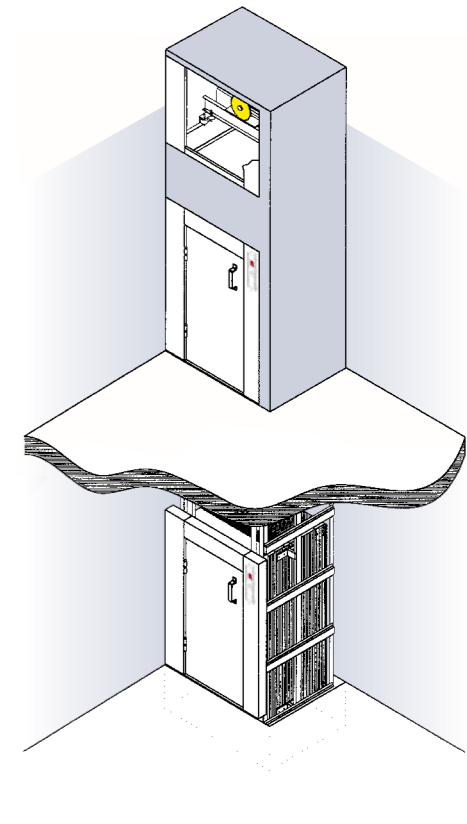

Swing doors serving at floor level

